



Actividades de
LECTOESCRITURA
para niños con
**SÍNDROME DE
DOWN**

Actividad:
Rompecabezas con Sílabas

Autoría



Este material ha sido creado por
@miabcdario

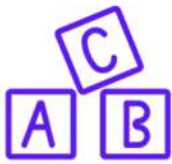

Miabcdario.com

Todos los derechos reservados.



52+ 999 649 638



@miabcdario



www.miabcdario.com



Lectoescritura

Al manipular letras para crear palabras, tu pequeño podrá desarrollar una comprensión más profunda de cómo se forman las palabras y cómo las letras se combinan para crear un significado.

A continuación, te presentamos algunos ejercicios que ayudarán a fomentar las habilidades cognitivas, motoras y lingüísticas de tu pequeño, fomentando la estimulación para futuras habilidades de lectura y escritura.



52+ 999 649 638



@miabcdario



www.miabcdario.com



Lectoescritura

"Uniendo Sílabas"

Objetivos:

Mejorar las habilidades de vocabulario y comprensión de palabras al unir fragmentos de imágenes con sílabas para formar palabras significativas.

Materiales:

- Imágenes fragmentadas con sílabas en cada parte de ellas.
- Lugar con suficiente espacio y sin distracciones.

Instrucciones:

- Explícale a tu pequeño que **van a formar palabras uniendo fragmentos de imágenes.**
- **Muestra ejemplos** de imágenes fragmentadas y cómo al juntarlas correctamente se forma una palabra.
- Proporciona una selección de imágenes fragmentadas con letras que formen diferentes palabras.
- **Puedes iniciar con palabras sencillas** e ir incrementando la dificultad conforme avance la actividad.
- Revisa junto con tu pequeño las palabras que han formado y corrige cualquier error.



Lectoescritura

Recomendaciones:

Imprime, recorta y enmica las tarjetas de esta actividad y utiliza un marcador de agua para marcar las respuestas, esto con la finalidad de que puedas borrarlo luego (gracias al enmicado).

De esa forma, **podrás reutilizar el material para practicar las veces que lo necesites.**



52+ 999 649 638



@miabcdario



www.miabcdario.com



Lectoescritura

PLANTILLAS



52+ 999 649 638



@miabcdario



www.miabcdario.com



Lectoescritura

A
BE
JA

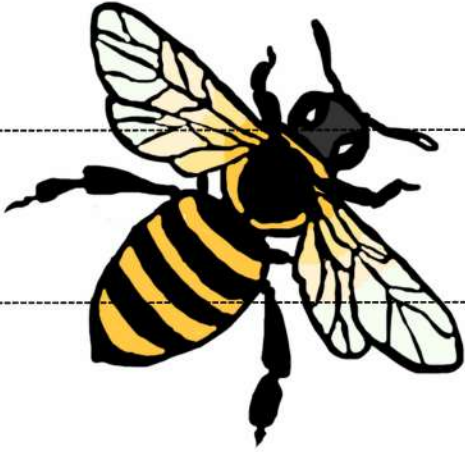

AL
TO

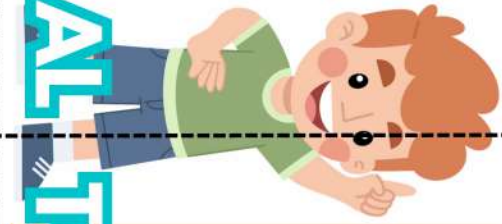

A
NI
LLO

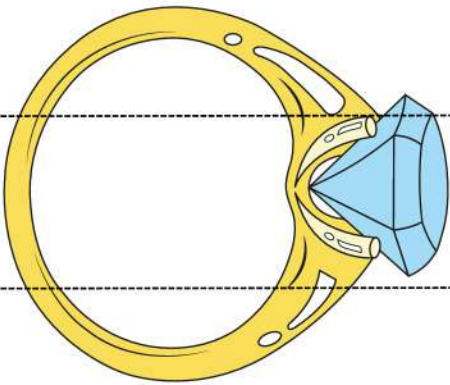

ÂR
BOL

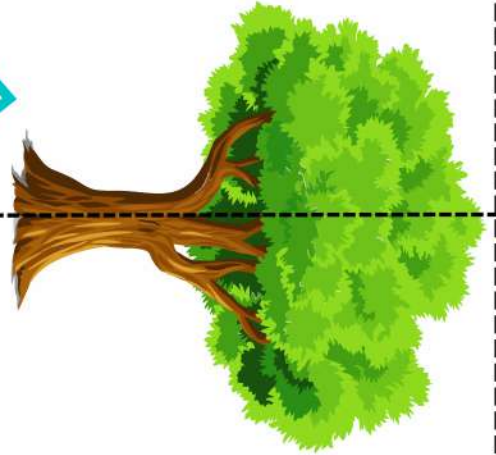

A
BRI
GO

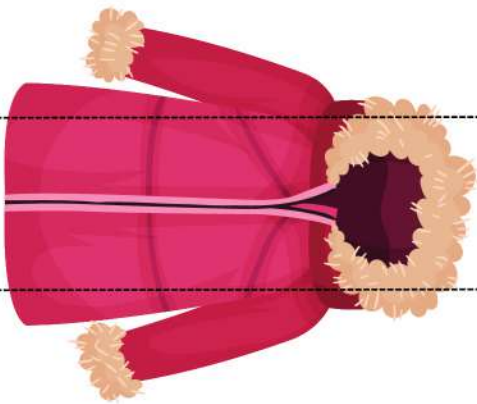

A
VIÃO

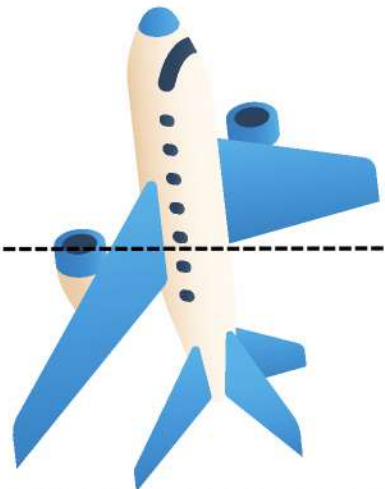

Lectoescritura

BA
LE
NA



BU
RRO

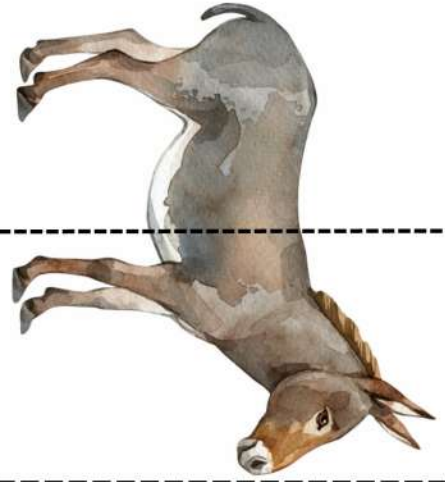

BO
RRE
GO

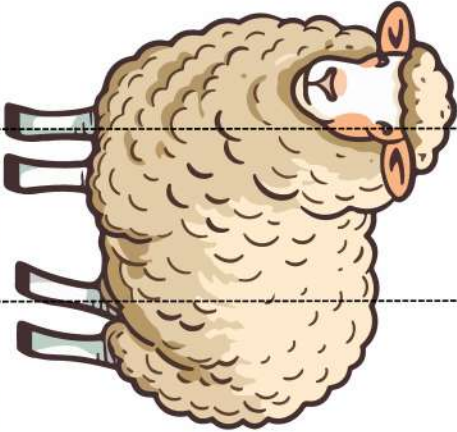

BAR
GO

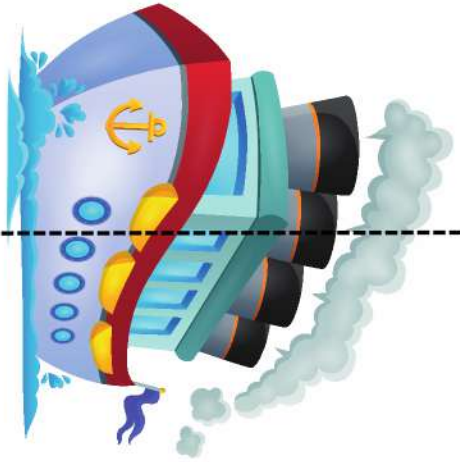

BO
TE
LLA



BRU
JA



Lectoescritura

CÁ
MA
RA

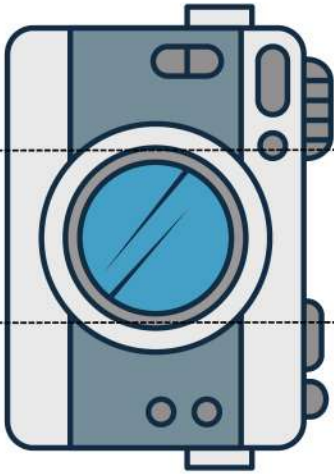

CA
SA

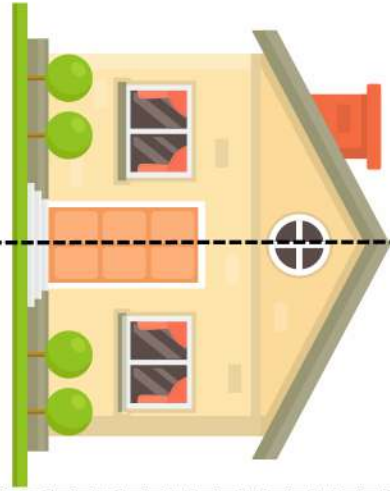

CA
BALLO

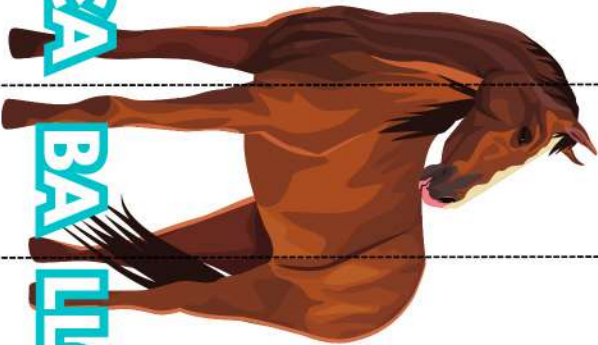

CA
RRO

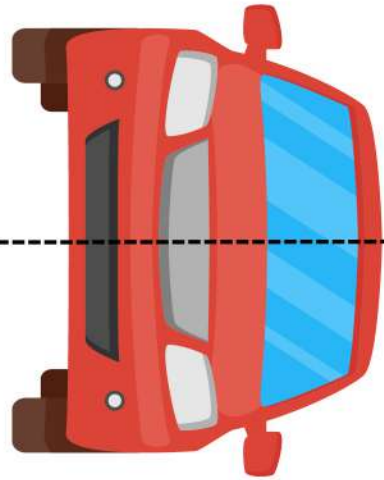

CA
BA
ÑA

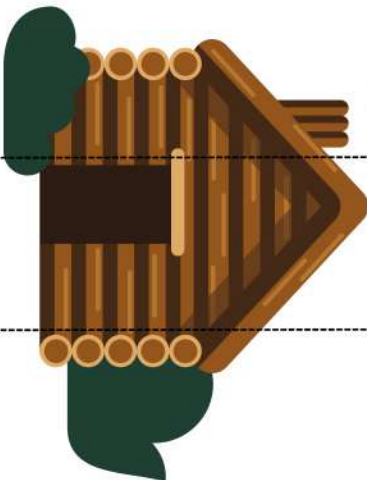

CER
DO

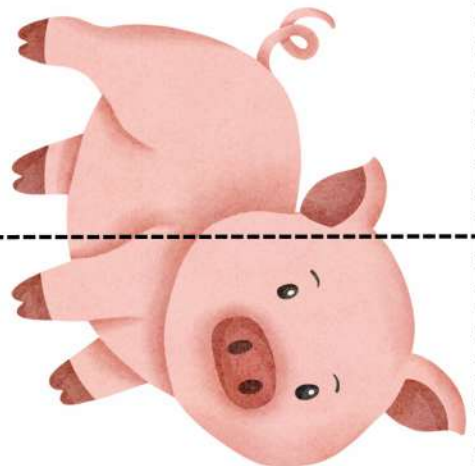

Lectoescritura

DI
NE
RO



DA
DO

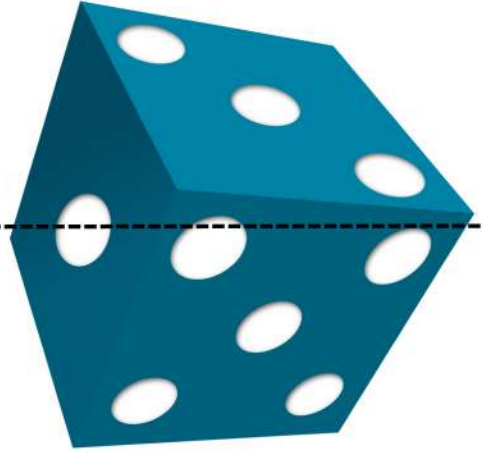

DIA
MAN
TE

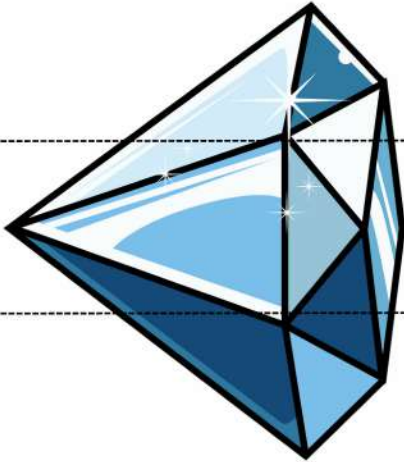

DIEN
TE



DEN
TIS
TA



DO
NA

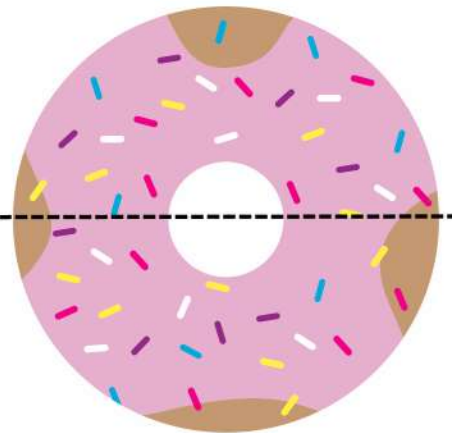

Lectoescritura

ES
PE
JO

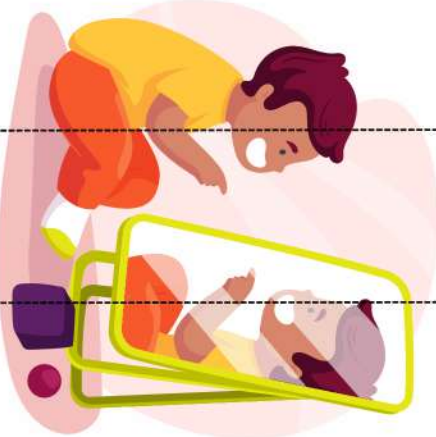

EL
FO

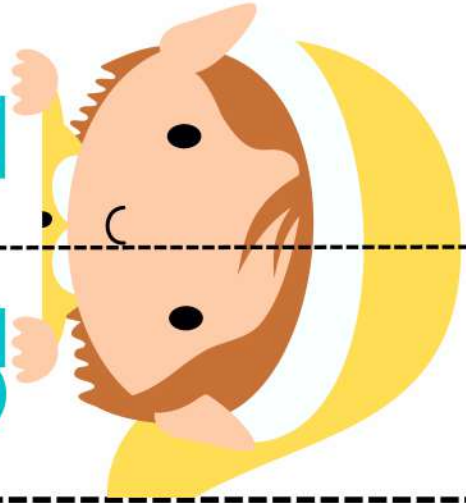

E
LO
TE

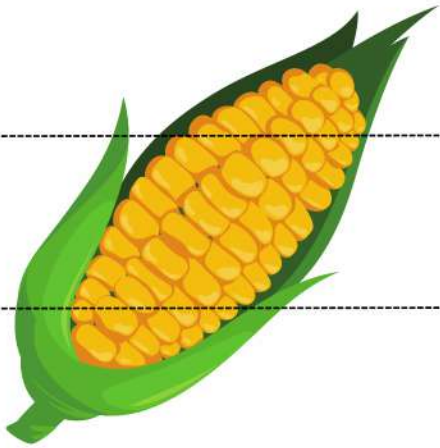

E
RROR



ES
TRE
LLA

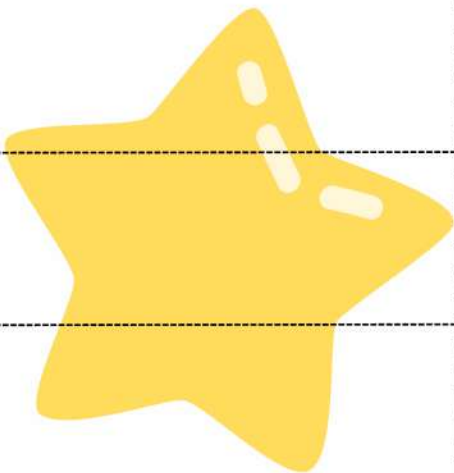

E
CO

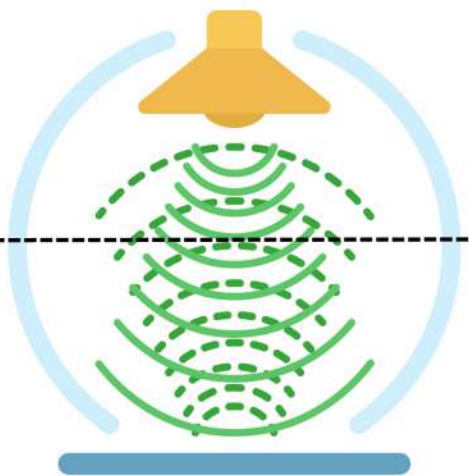

Lectoescritura

FLA
MEN
GO

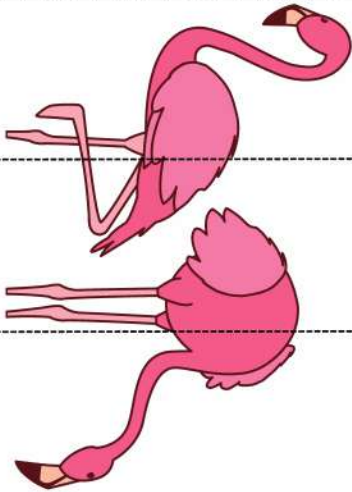

FO
GO

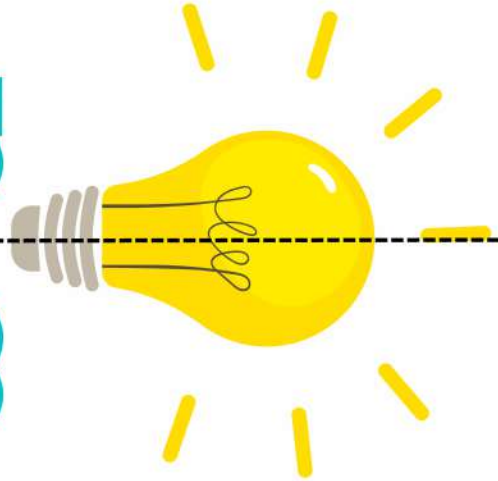

FRAM
BUE
SA

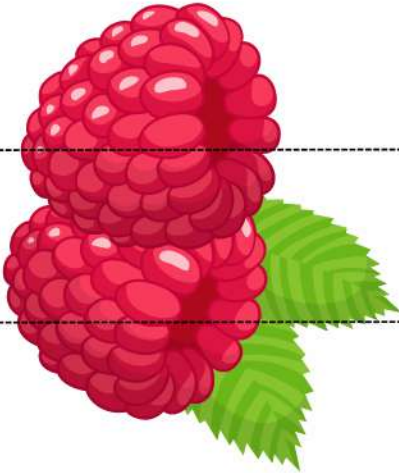

FO
GA

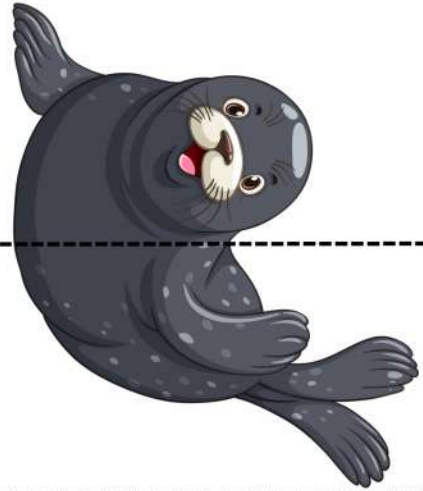

EAA
MI
LIA

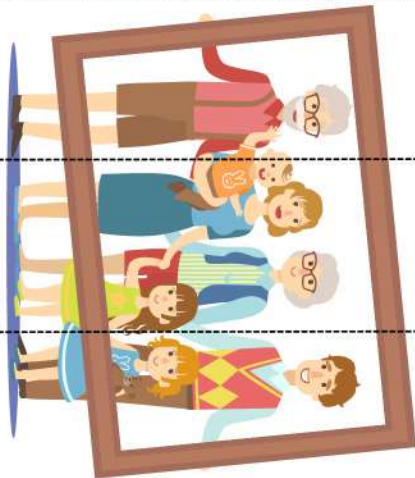

FUE
GO

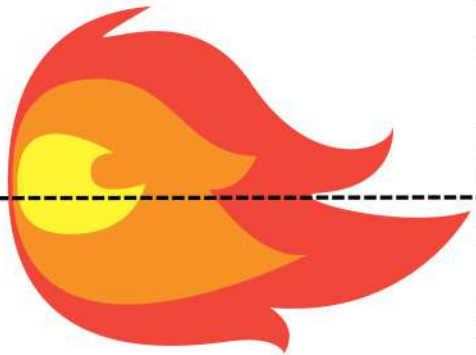

Lectoescritura

GO
RI
LA

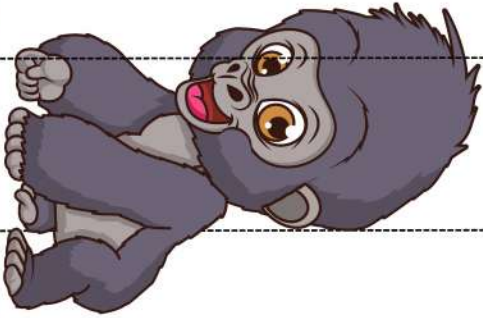

GA
TO

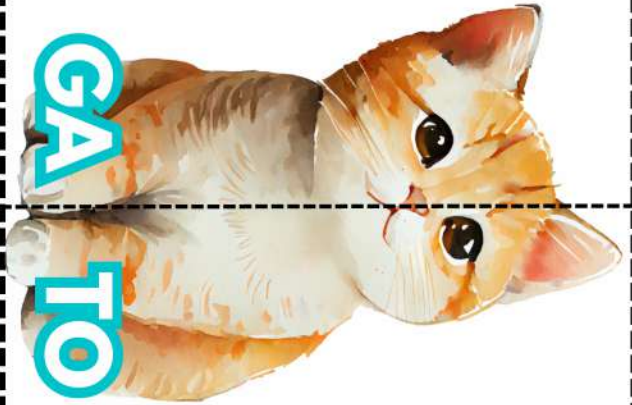

GA
RRA
EA

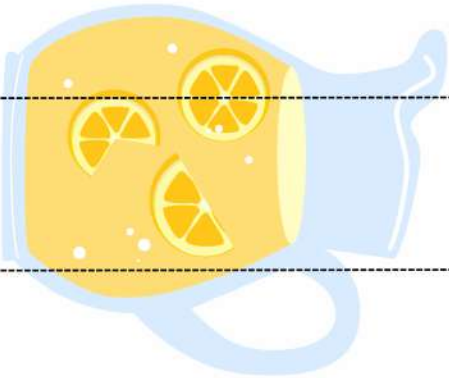

GO
RRA

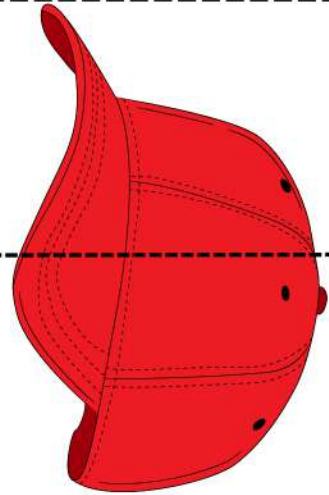

GI
RA
SOL



GO
MA

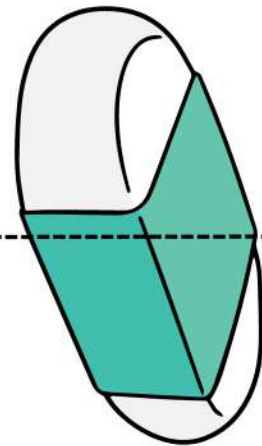

Lectoescritura

HE
LA
DO

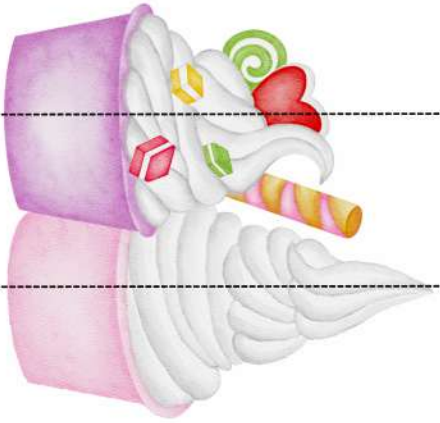

HUE
VO

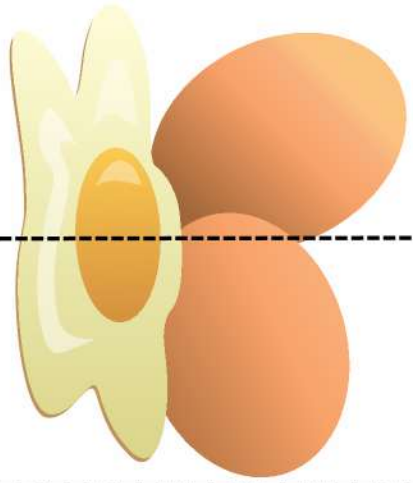

HOR
MI
GA

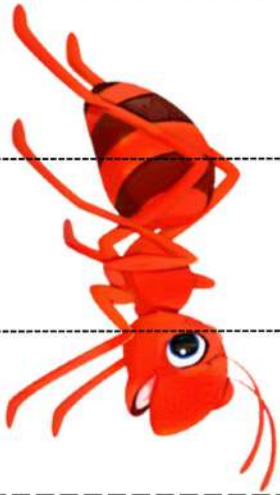

HIE
LO

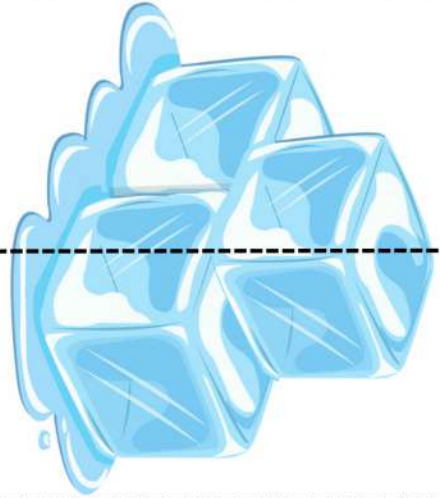

HOS
PI
TAL

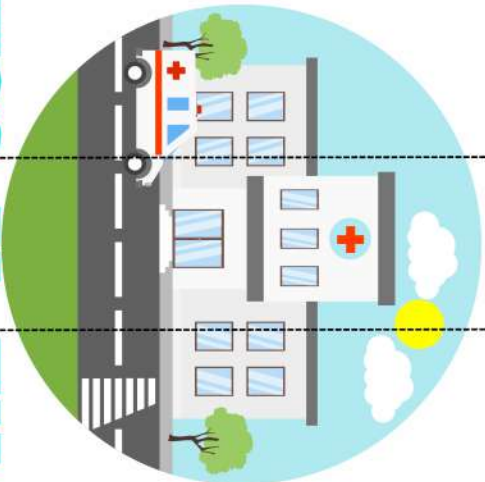

HA
DA



Lectoescritura

I
GLE
SIA

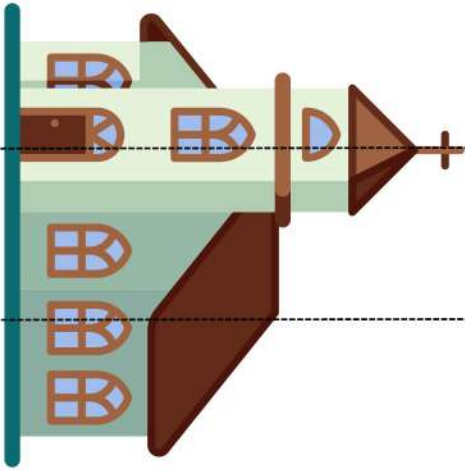

I
GLU



I
GUA
NA



I
MÂN

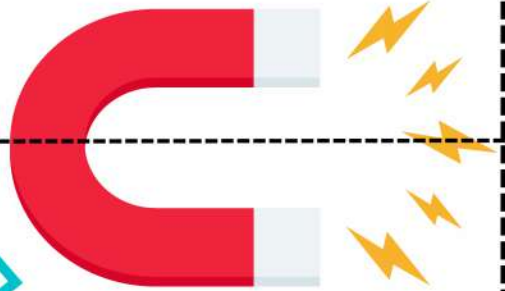

IN
VIER
NO

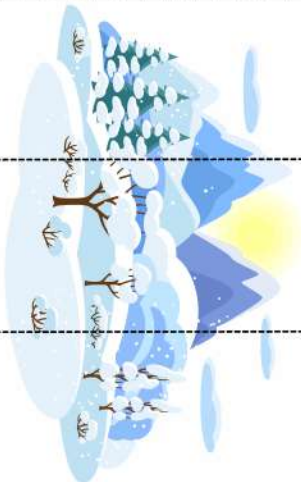

IS
LA

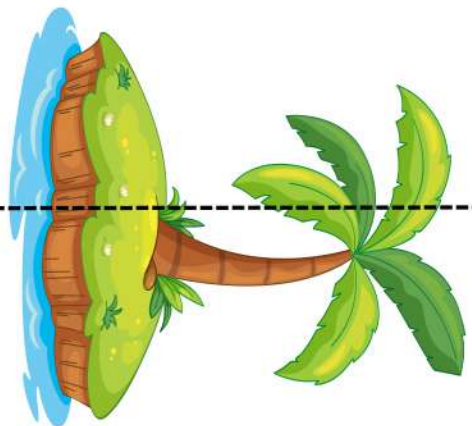

Lectoescritura

JU
RA
FA

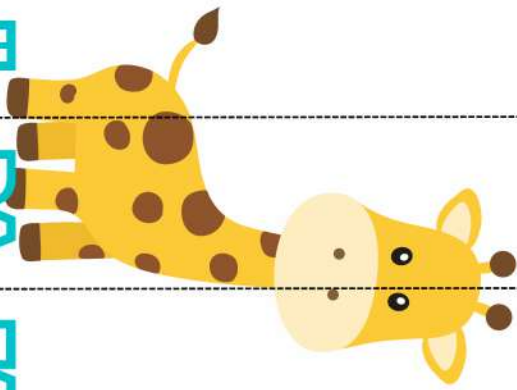

JA
BÓN

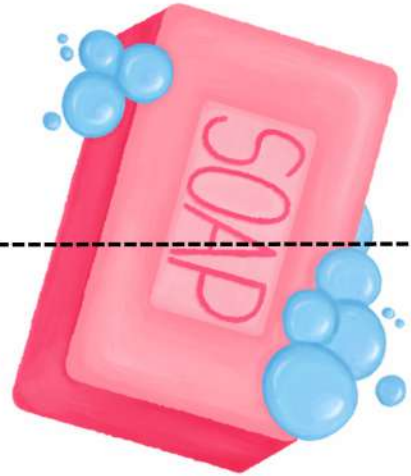

JU
GUE
TES



JU
GO

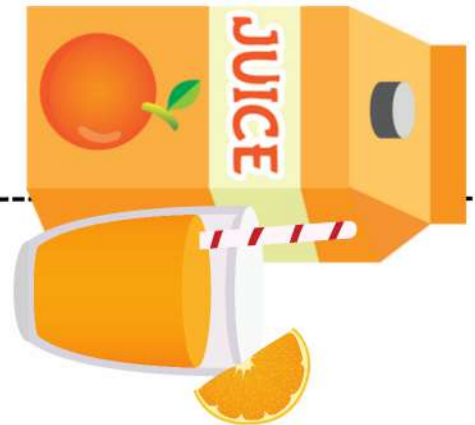

JE
RIN
GA



JO
YA

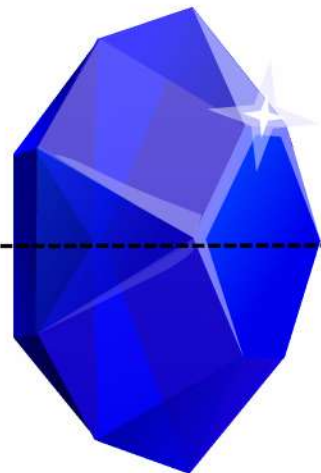

Lectoescritura

KO
A
LA

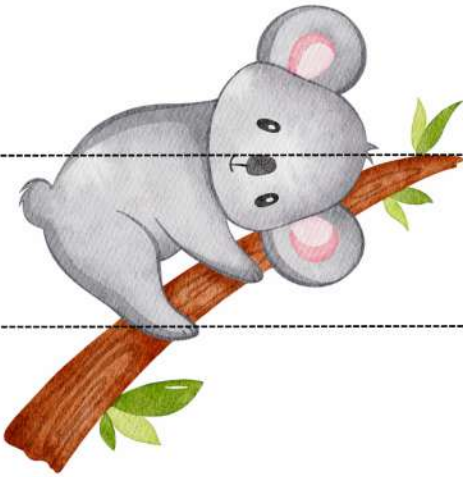

KI
WI

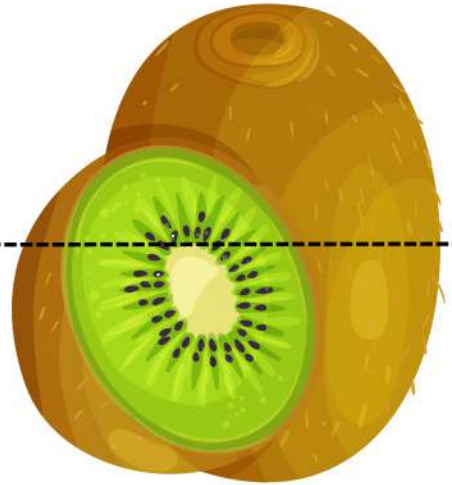

KI
MO
NO

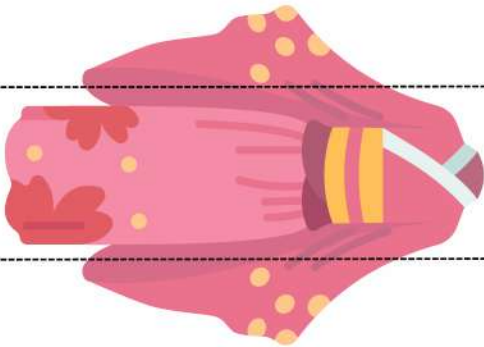

KIN
DER



KA
RA
TE

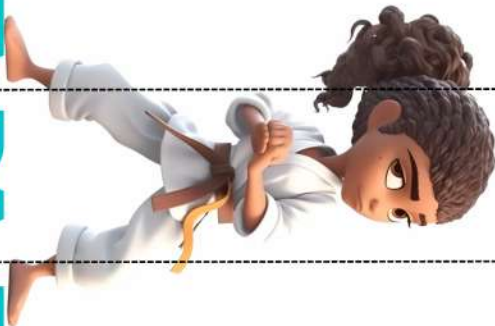

KIOS
CO

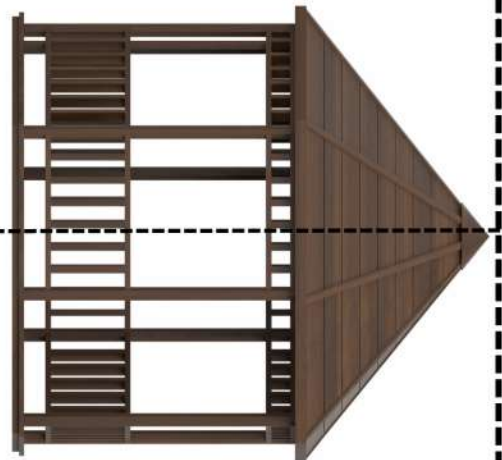

Lectoescritura

LI
BRE
TA



LU
NA

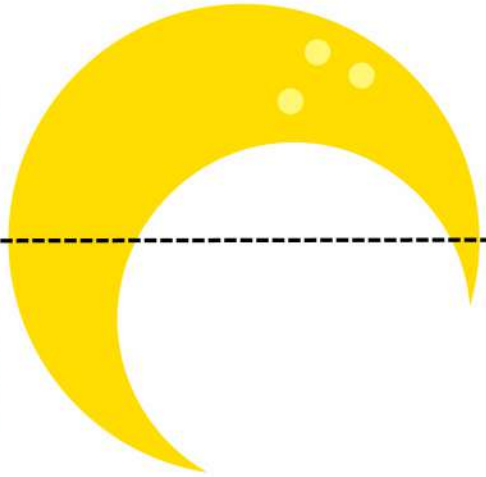

LÂM
PA
RA

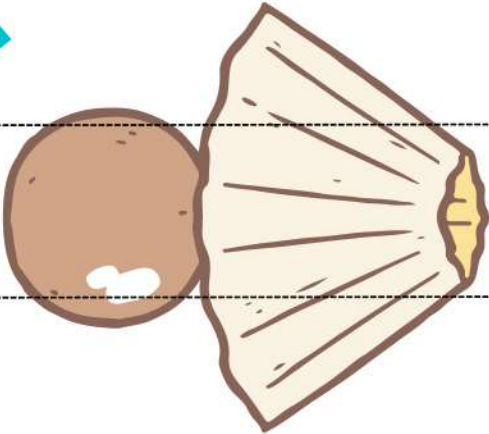

LÂ
PIZ

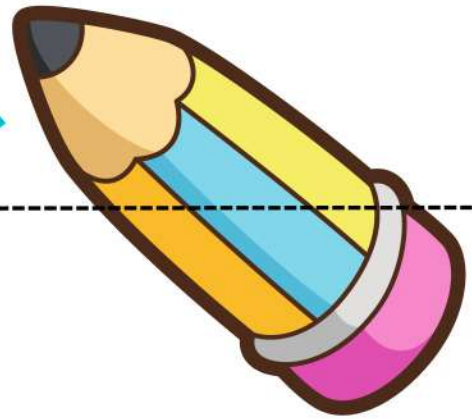

LE
CHU
GA



LO
BO

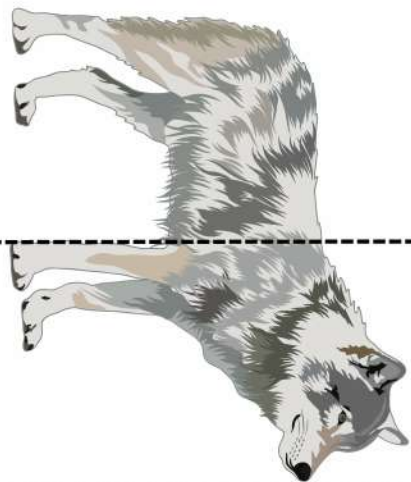

Lectoescritura

MU

ÑE

GA

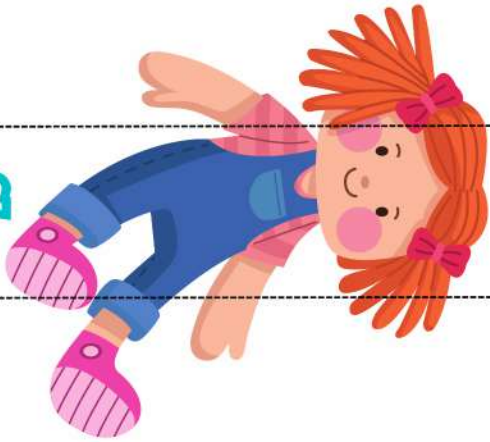

MO

NO

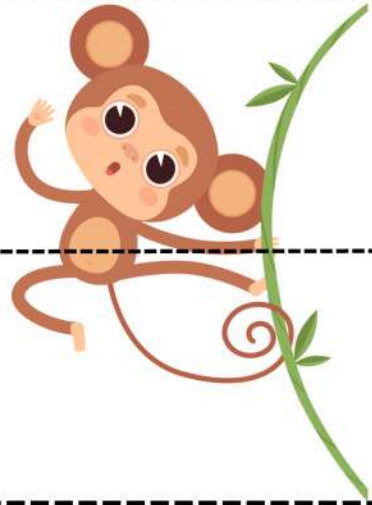

MO

CHI

LA

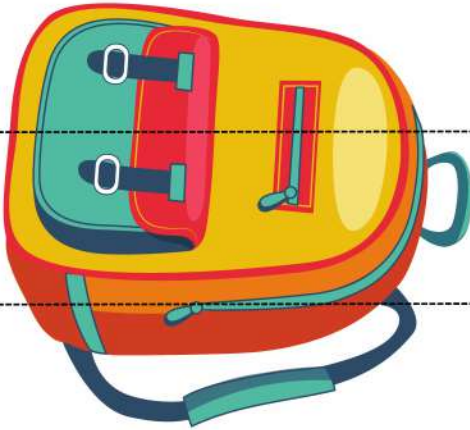

MA

NO

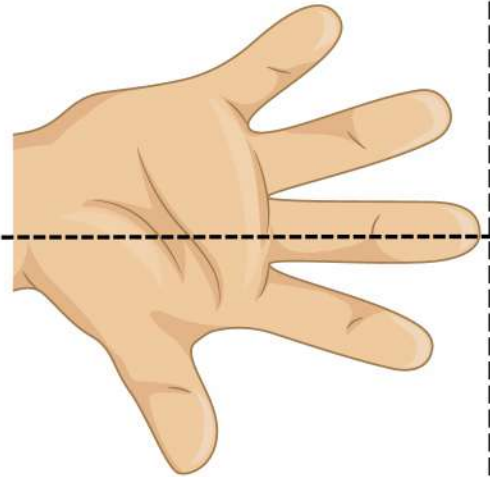

MO

LI

NO

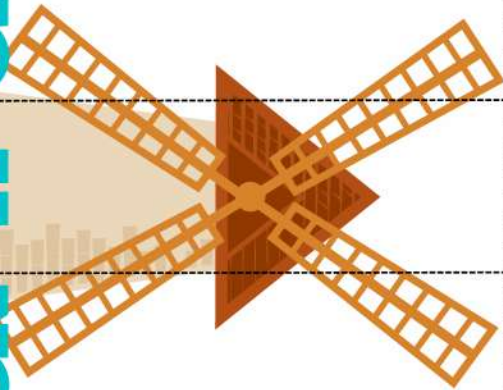

MUN

DO

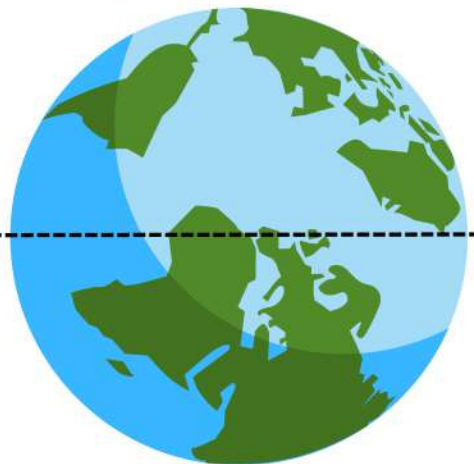

Lectoescritura

NÚ
ME
ROS

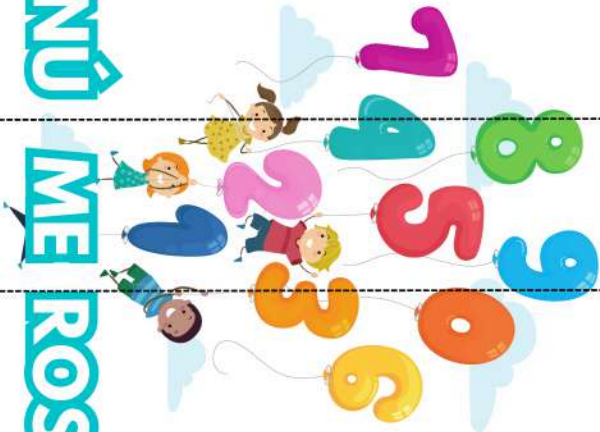

NU
BE

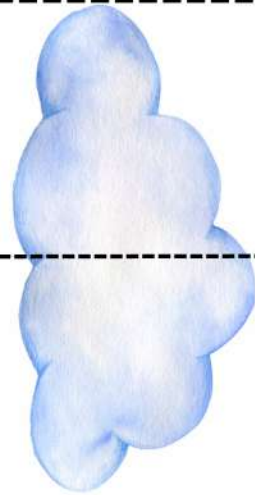

NA
TA
GIÓN



NI
DO

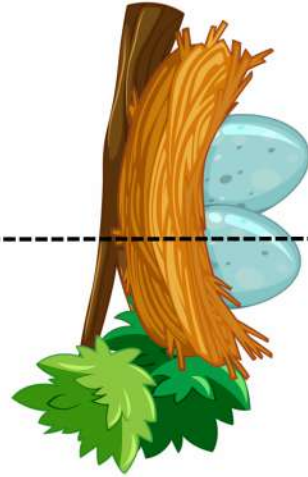

NA
VA
JA

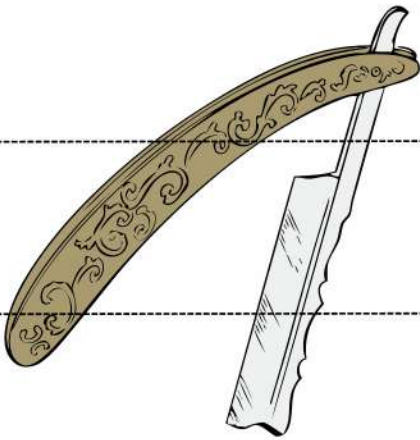

NI
ÑO

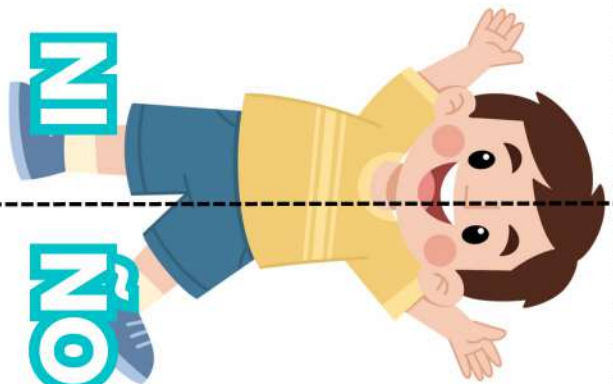

Lectoescritura

○ VE JA

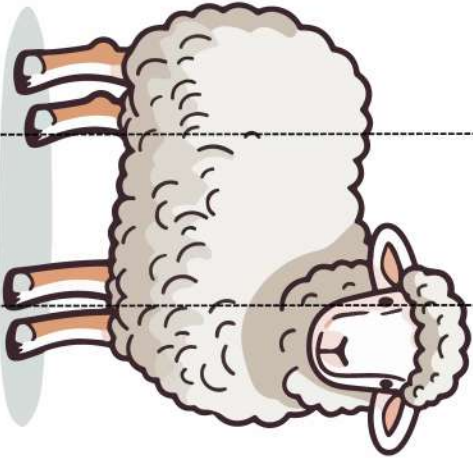

○ SO

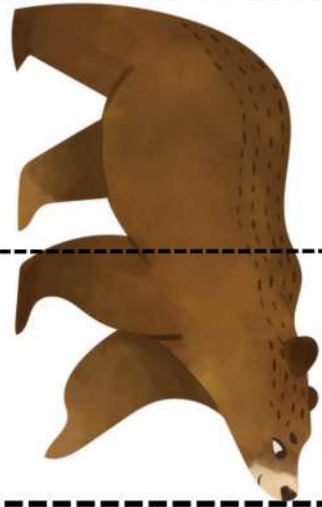

○ R QUES TA



○ JO

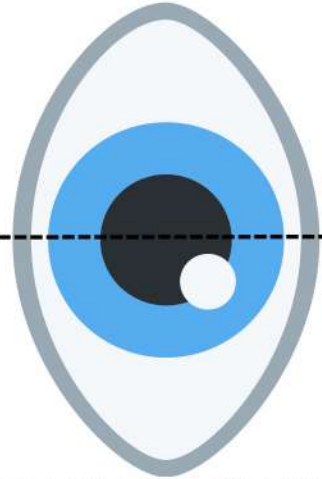

○ TO ÑO

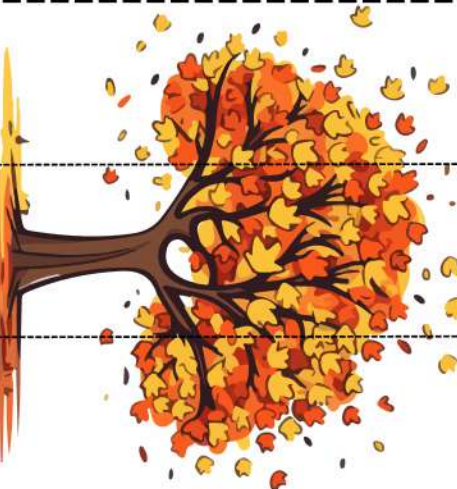

○ LA

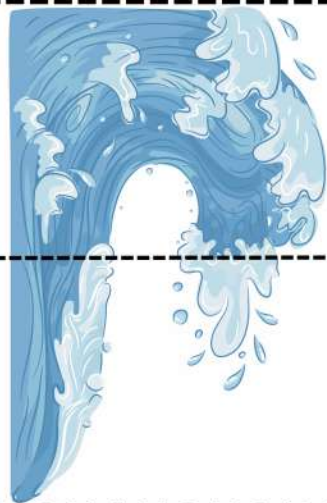

Lectoescritura

PI
ÑA
TA

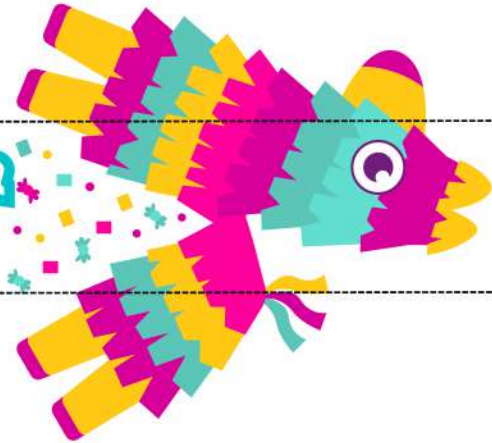

PE
RRO



PA
LE
TA

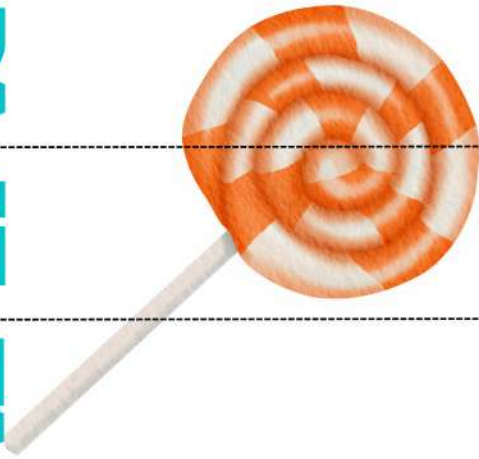

PO
ZO

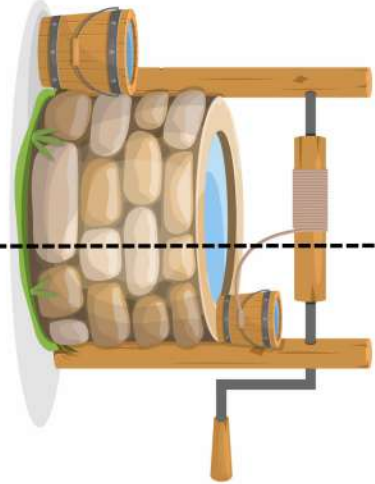

PE
LO
TA

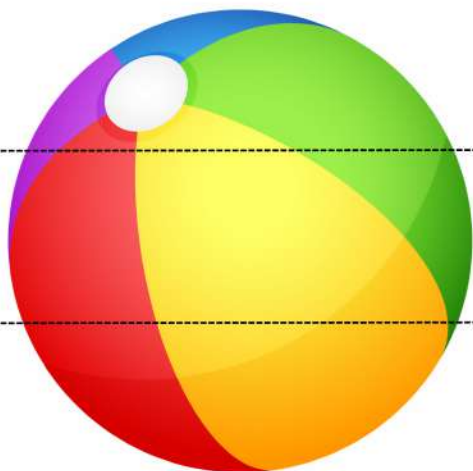

PA
TO

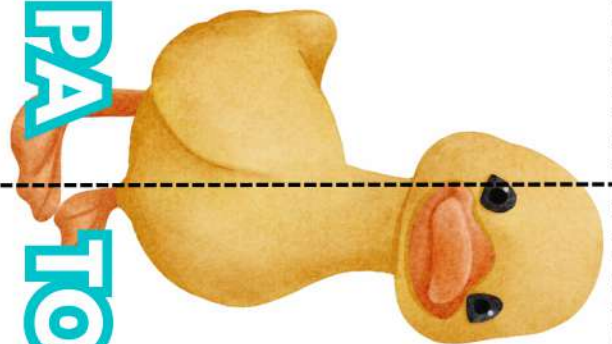

Lectoescritura

QÜÍ
MI
CA

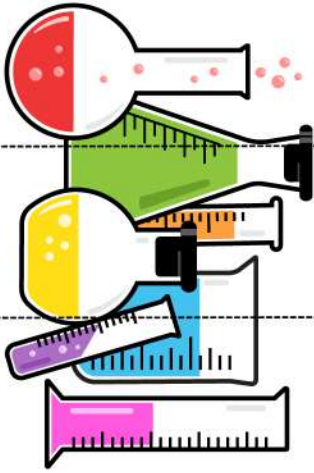

QÜE
SO



QÜE
MA
DO



QÜE
BRAR

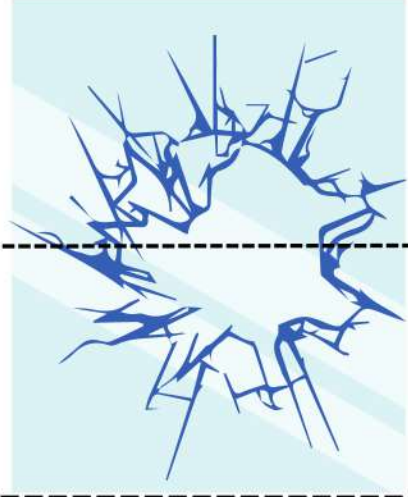

QÜE
RU
BÍN

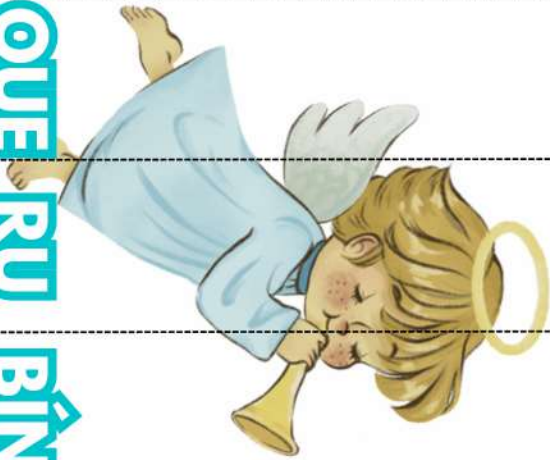

QÜIN
CE

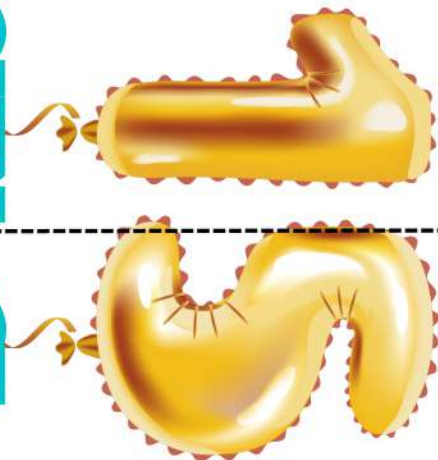

Lectoescritura

RO PE RO

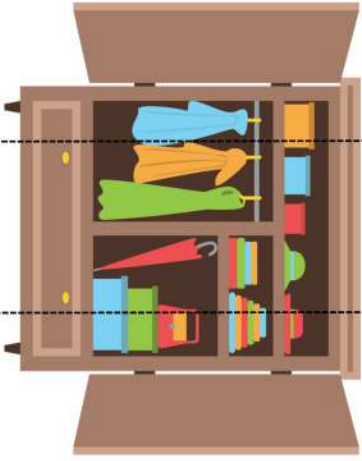

RO SA

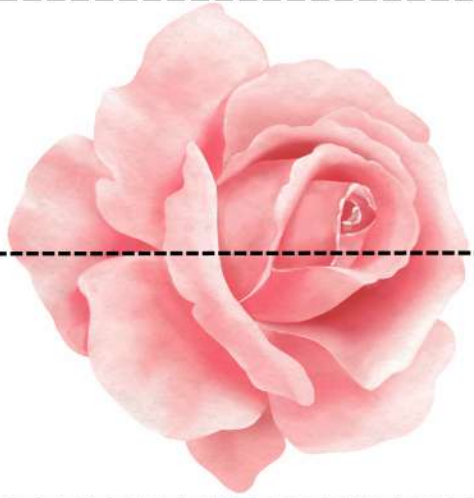

RA QUE TA



RI SA

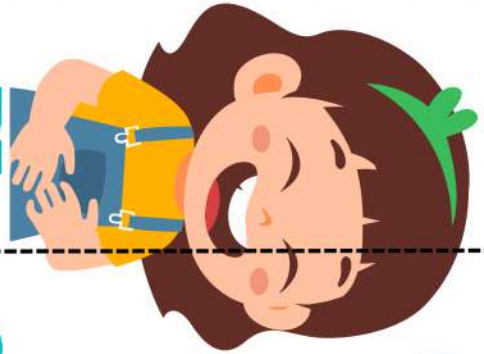

HA HA HA

RO DI ULA

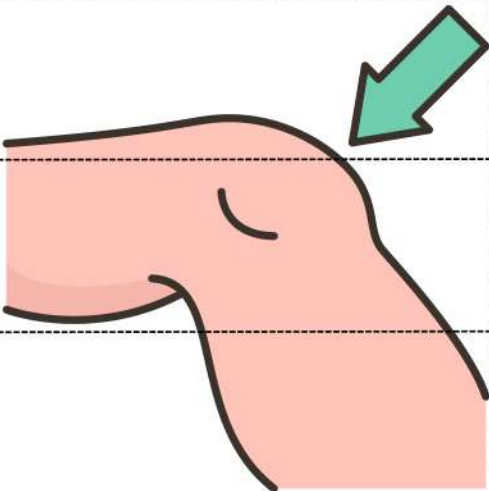

RA NA

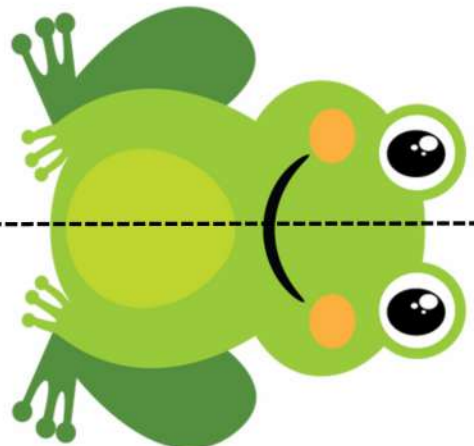

Lectoescritura

SA
LE
RO



SI
LLA

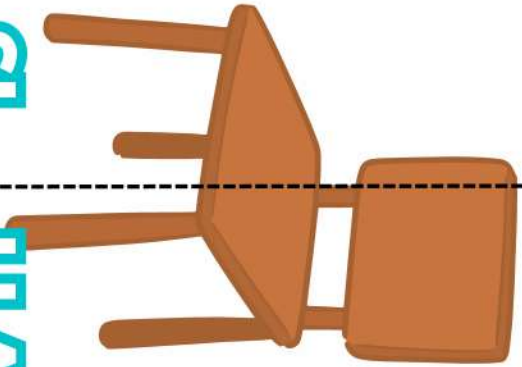

SOM
BRE
RO

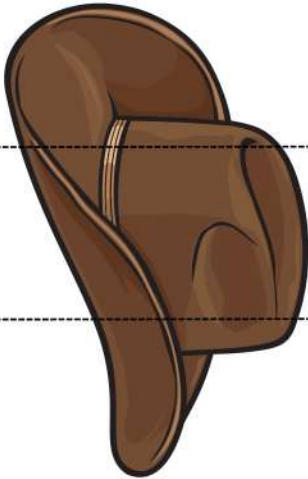

SO
PA

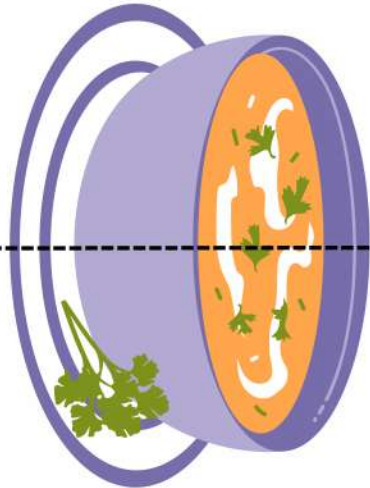

SIL
BA
TO

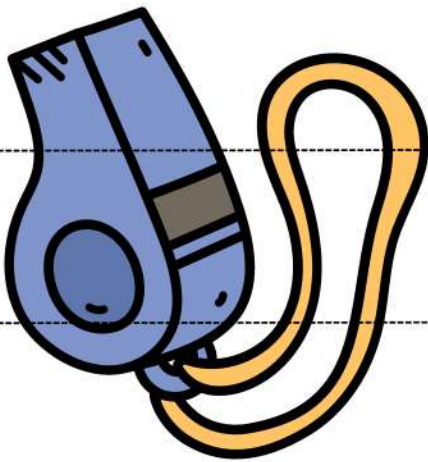

SO
GA



Lectoescritura

TO
MA
TE

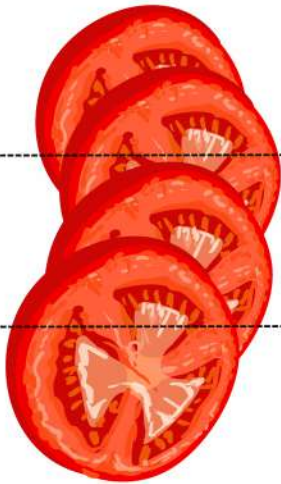

TA
ZA

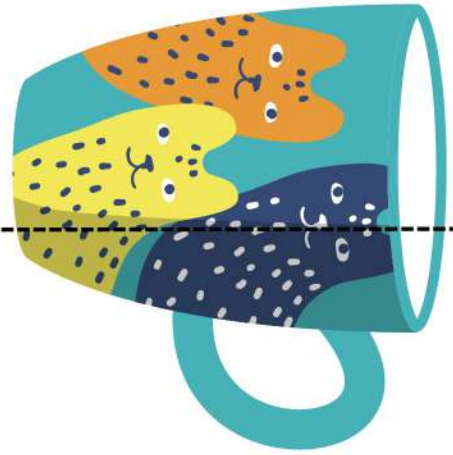

TOR
NI
LLO

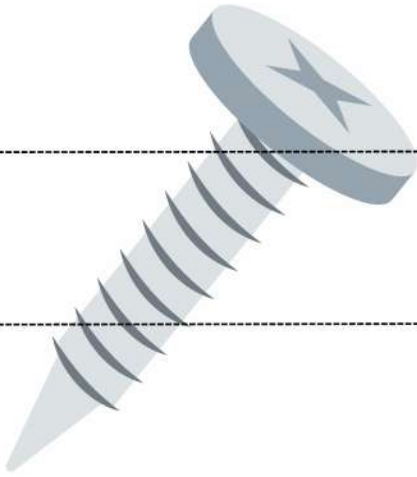

TO
RO

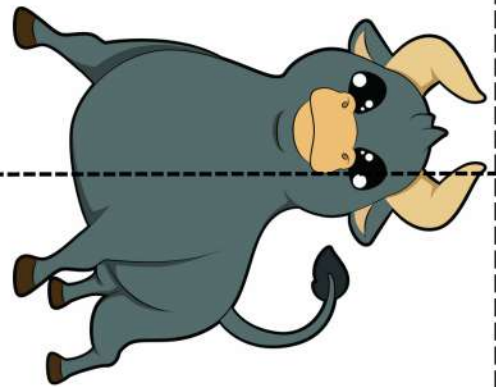

TE
TE
RA

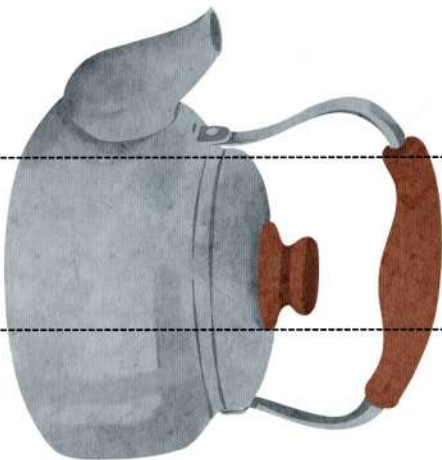

TIN
TA

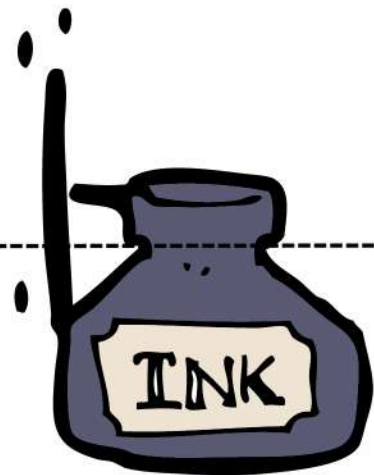

Lectoescritura

UR
GEN
TE



U
VA



UR
NA

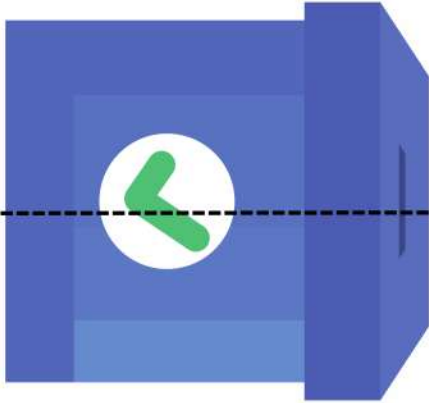

U
ÑA

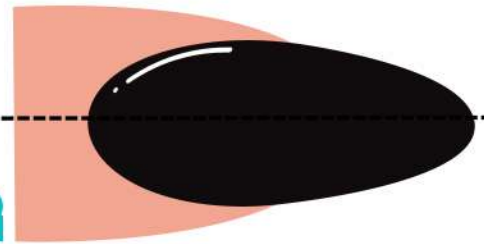

U
TE
RO

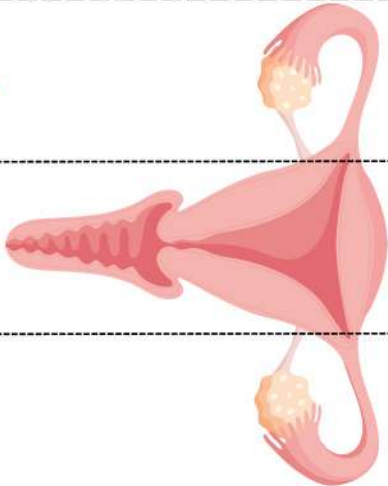

U
NO

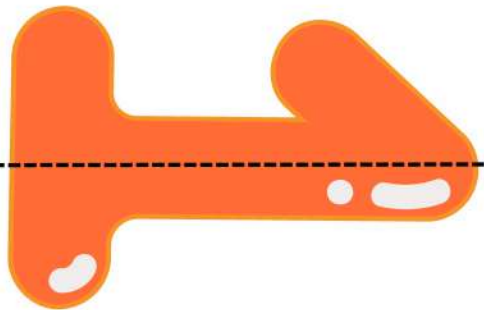

Lectoescritura

VE
LE
RO

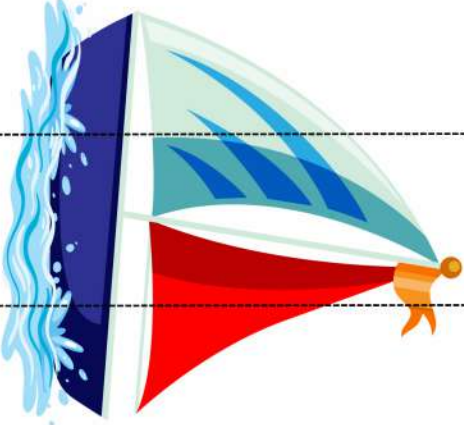

VA
GA

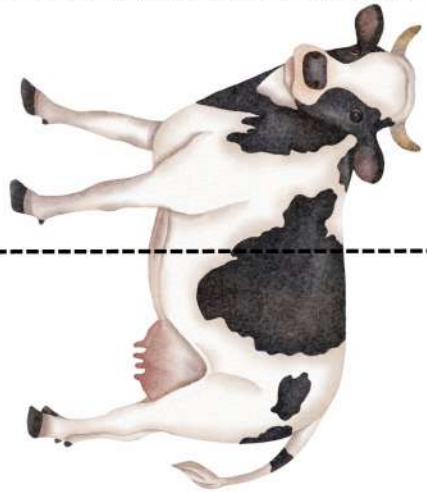

VA
SI
JA

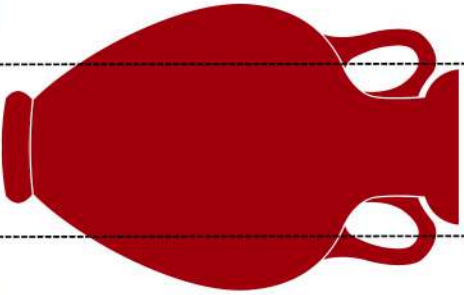

VI
NO

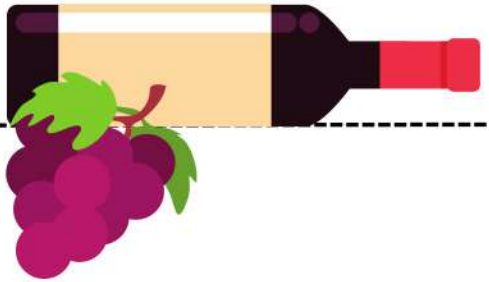

VEN
TA
NA

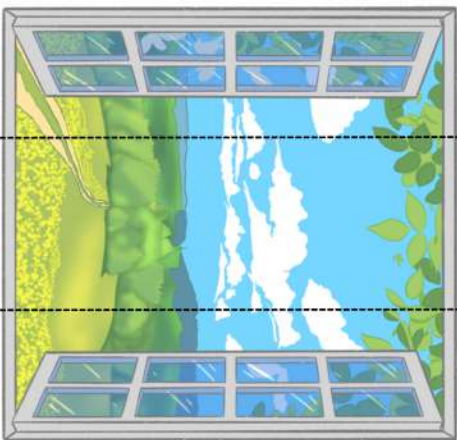

VE
LA

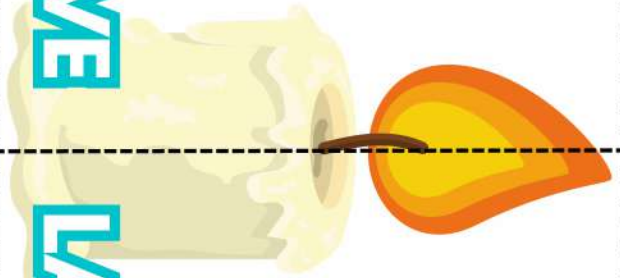

Lectoescritura

WA
SA
BI

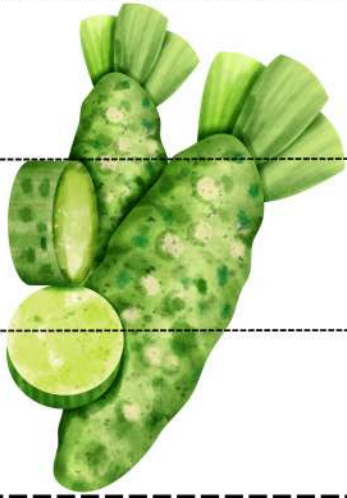

WA
F
E

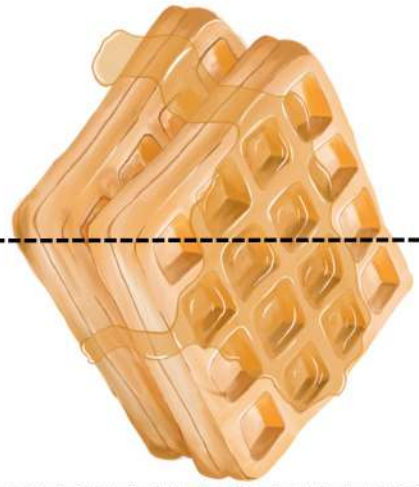

YO
GURT

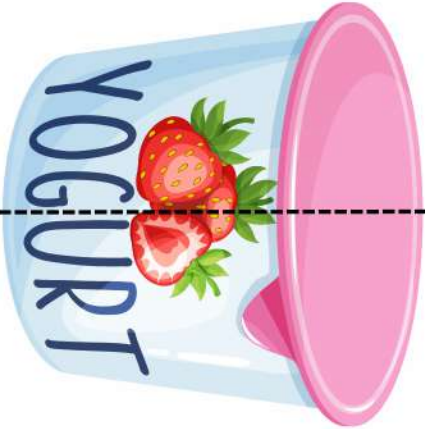

YO
YO

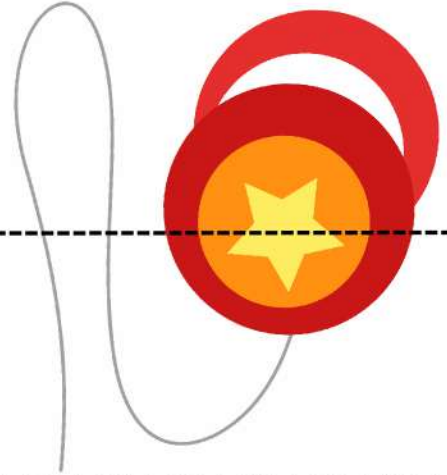

ZAN
JA

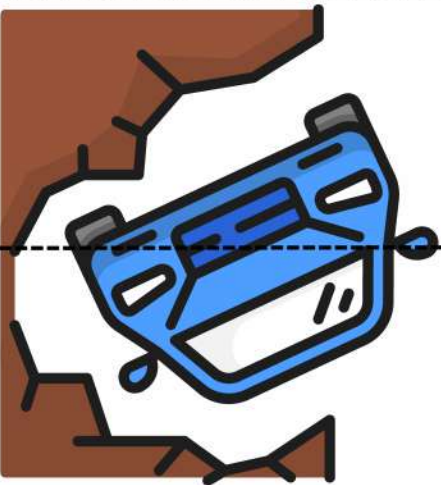

ZO
RRO

